

MINCO MINTEMP II AND MINTEMP II MEMORY OPERATING INSTRUCTIONS



INTRODUCTION

The Mintemp is a portable indicator designed to interpret the output from a standard dip thermocouple and display the measured temperature. Each Min-temp is prepared in advance by Minco for immediate operation and is supplied with a suitable lance for each application. (If a spare or alternative lance is required, contact your nearest Minco representative). The unit is powered by a rechargeable NiMH battery pack and a separate mains charger is normally supplied with the instrument (alternatively a Dry-cell AA battery pack can be specified at the time of ordering). The Memory version of the Min-temp incorporates an in built memory chip, which allows up to 1000 readings to be recorded with time and date of measurement for subsequent transfer to a PC.

BASIC OPERATION

To take a measurement with the Mintemp, connect a thermocouple to the dip lance and press the operate button on the front panel. (The Memory version will indicate the time followed by the station number set for the following reading. To change the station number press the button on the right hand side of the instrument case once for each station) The display will then indicate the ambient temperature if a good circuit is made and the Green LED to the right of the display. If the display indicates flashing dashes "- -" the thermocouple is either open circuit or poor contact has been made. The 'operate' button can be released at this point if preferred, as the unit will remain switched on for the duration of the measurement. Immerse the thermocouple in the molten metal to the required depth, the real time temperature will be indicated on the display and the Amber LED will show measurement in progress. As the reading stabilises and a plateau is detected the Red LED will light and the buzzer if fitted will sound. Remove the thermocouple from the melt and note the reading - the unit will switch off automatically (in the case of Min-temp Memory the data is stored prior to switch off).

TECHNICAL INFORMATION

The Min-temp can be set to operate for thermocouple types R90, S90, K90, R48, S48, K48, B or N via soldered links and DIL switches on the main board (see appendix A.).

The instrument incorporates an integrating analogue to digital converter designed to filter out electrical interference. Cold junction compensation is automatic and a microprocessor is used to linearise and standardise the values to International thermocouple tables, before displaying the resulting temperature in either Fahrenheit or Celsius. The instrument scans the integrated values every 400ms. After the temperature exceeds a 200C threshold, it compares consecutive readings displaying the average until a steady temperature is detected which then locks on the display and is held during the removal of the thermocouple from the melt.

Switching on the instrument activates the start of a 15 second timer. On immersion of the thermocouple into the melt a threshold of 200C is exceeded. The instrument remains powered up until removed from the melt. A further 15 second timer is set when the input temperature falls by 200C from the held reading to allow time for the operator to confirm the result. The instrument then switches off automatically .

CHARGING OR REPLACEMENT BATTERIES

The Min-temp will warn of a low battery voltage before any effect on the validity of the measurement. The display will show four dots below the measurement display "...". If rechargeable batteries are fitted the unit should be charged using the Minco charger supplied. 5 x 40mAh NiMH cells are fitted and a full charge should be achieved in 10 hours.(NiMH cells have no retained charge memory and as such can be charged as frequently as required without waiting for low battery warning).

If dry-cell batteries are fitted they can simply be replaced with 4 x AA size alkaline cells.

CALIBRATION

A qualified instrument engineer should only carry out calibration of the instrument. The input should be connected to the connector block inside the termination box. Zero can be adjusted by the ZERO potentiometer and range by the SPAN potentiometer. (cold junction compensation is automatic).

SCHEMATIC OF THE MIN-TEMP / MIN-TEMP MEMORY

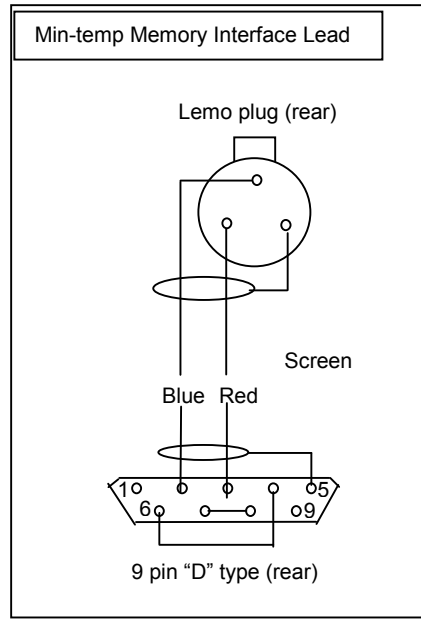
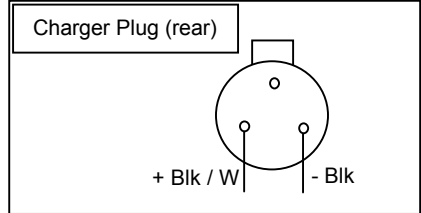
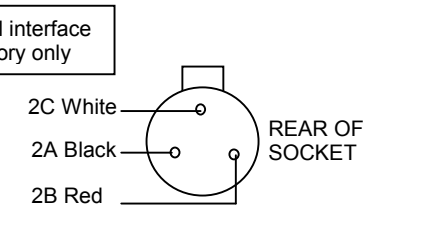
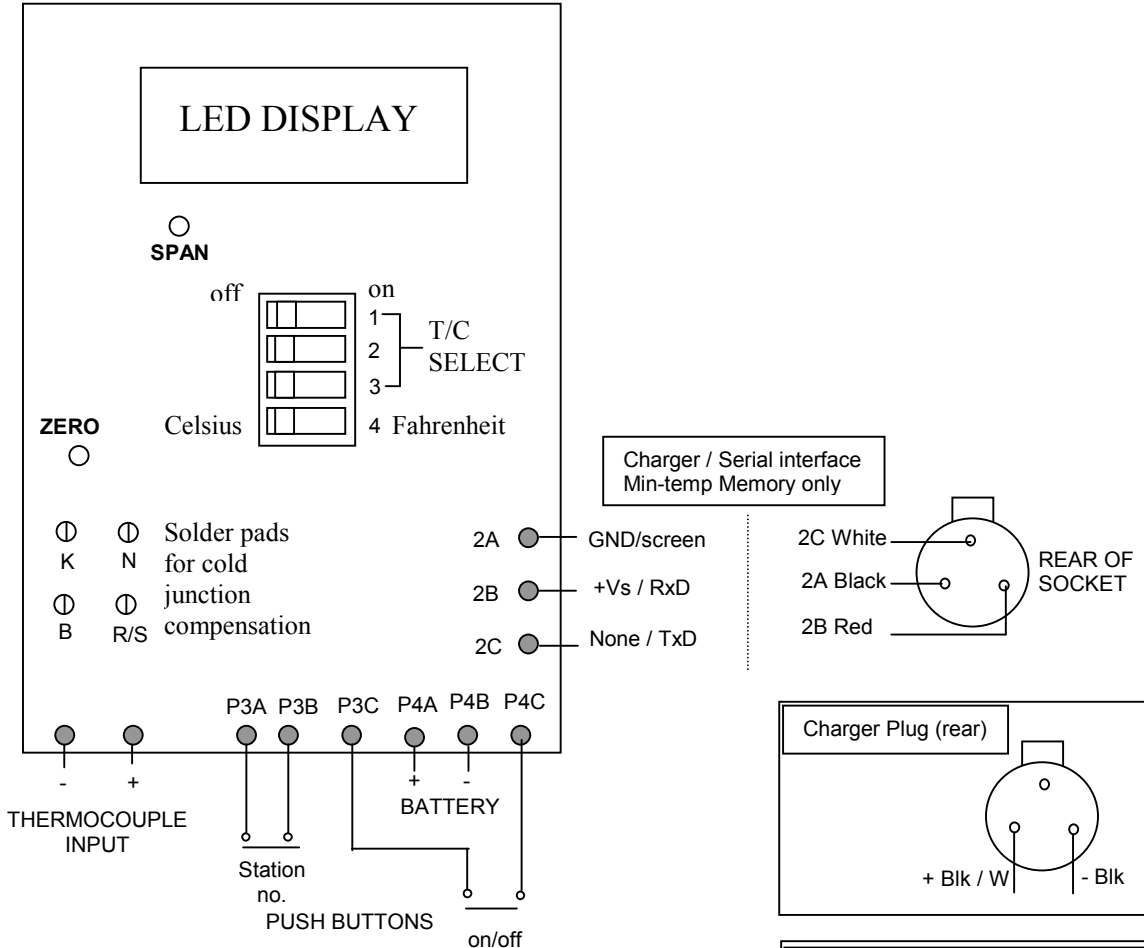

Thermocouple selection								
Switch	R-90	S-90	K-90	N	B	K-48	R-48	S-48
1	OFF	ON	OFF	ON	OFF	ON	OFF	ON
2	OFF	OFF	ON	ON	OFF	OFF	ON	ON
3	OFF	OFF	OFF	OFF	ON	ON	ON	ON
4	Celsius / OFF		Fahrenheit / ON					

Note : - If changing thermocouple types , special care should be taken to re-solder the correct cold junction pads. The interconnecting cable from the board to the connection terminals must be replaced for the correct T/C type.

MINTEMP MEMORY INTERFACE INSTALLATION

The Min-temp Memory is supplied with free "Down load" software for use with a PC running Windows 3.11, 95, 98 or NT.

To install under 3.11 place Min-temp disc in drive A: open File Manager select Run and type **A:\setup** and follow the on screen commands.

To install under Windows 95, 98 or NT place Min-temp disc in drive A: at Start Menu select Run and in box type **A:\setup** and follow the on screen commands.

The install function will automatically create a short cut which can be copied (dragged) to the desktop if required. To run the software double click on the **M** icon. The screen will appear as below.

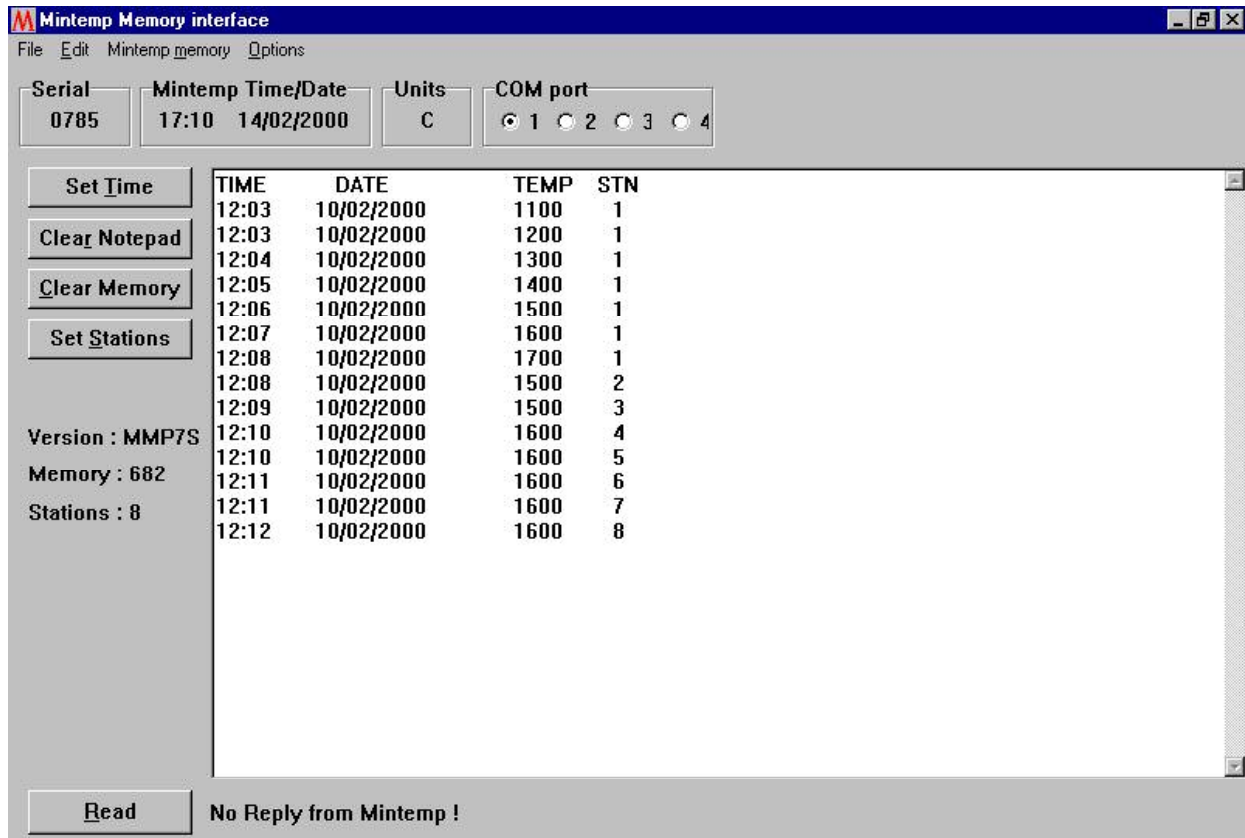

MINTEMP MEMORY OPERATION

PREPARING THE MINTEMP MEMORY FOR OPERATION

Setting the COM port

Connect the interface lead between a free serial COM port on the PC and the download/charger socket on the instrument (the lead is supplied with a 9 pin "D" type plug, a 25 pin adapter is available). Select the COM port number used, by clicking in the appropriate circle on the interface program. Power up the Min-temp and click on the "Read" button on the interface program. The interface should show the serial number, date, time and any measurements in the instruments memory (if interface displays text "No reply from Min-temp" check that the instrument was switched on and the correct COM port is selected.)

Setting the Min-temp internal time clock

To set the time in the Min-temp, connect the interface lead between the instrument and the PC. Ensure the correct **COM port** is selected, power up the Min-temp and click on the "**set time**" button. The computer time will be transferred to the instrument and when complete, confirmation will appear beside the "**read**" button. The Min-temp incorporates an in-built clock that is powered by a battery mounted on the printed circuit board. This battery will give many years of operation before replacement is required.

To set up the station number option

The instrument can be set to identify up to 8 station numbers to aid data correlation. To switch on the station number option click on the "**set station**" button on the screen, a box will appear with a selection of 1 to 8. Click on the total number of stations required and the station number option is set. To select a station, power up the Min-temp and the display will show the last station number used. Pressing the button on the side of the instrument will increment the station number. The station number can be set prior to each measurement (note if the "**set station**" button on the interface software is set to 1, the station number option is switched off).

To download and clear the Mintemp Memory

Connect the interface lead and ensure the correct COM port is selected, power up the Min-temp and click the "**read**" button to download the data. The data can be printed out directly from the interface using the File / Print commands from the Menu, or saved as a .TXT file using File/Save. If graph plotting is desired the data can be Cut and Pasted or imported into a spreadsheet program (e.g. Microsoft Excel). Once downloaded the Min-temp Memory still retains the data until cleared by clicking the "**clear memory**" button, when the instruments internal memory is full the unit will display "**FULL**", however the unit will continue to store new readings but will erase the oldest reading in it's memory. The "**clear notepad**" command is used to remove data from the screen.